

Powerscreen® Trakpactor 500

Horizontal Impactor

SPECIFICATION - Rev 11. 01-01-2017

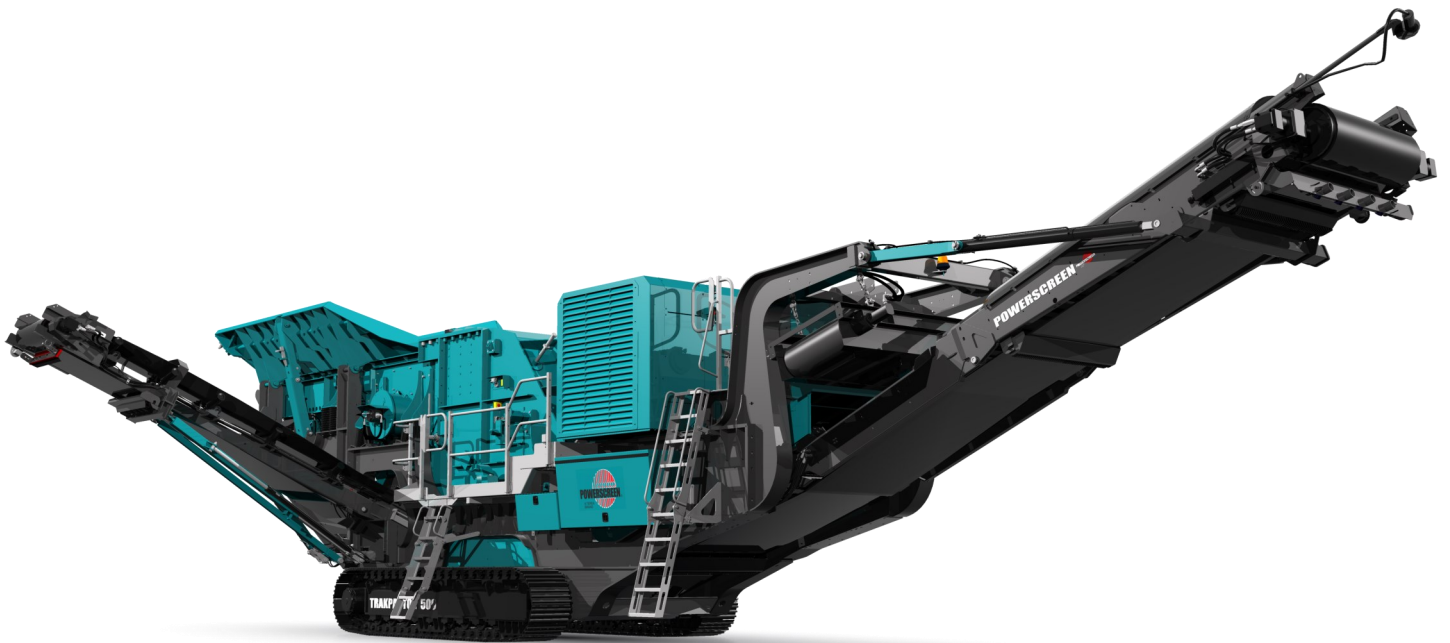

Powerscreen® Trakpactor 500

SPECIFICATION - Rev 11. 01-01-2017

Specification		Trakpactor 500 Standard
Total weight		52,580kg (115,919lbs) including side conveyor & magnet
Transport	Length	17.3m (56' 8")
	Width	3m (9' 10")
	Height	3.8m (12' 6")
Working	Length	17m (56')
	Width	3m (9' 10") 7m (23') with side conveyor deployed
	Height	4.1m (13' 6")
Crusher type:		Twin apron 4 bar impact crusher, feed opening 1360mm x 800mm (54" x 32")
Power unit:		Caterpillar C13 328kW (440hp) or Scania DC13 331kW (450hp)
Paint colour:		Blue RAL 5021, Grey RAL 7024, Black RAL 9005

Features & Benefits

The Powerscreen® Trakpactor 500 horizontal shaft impactor is designed for processing soft to medium-hard primary & secondary materials such as natural rock & construction derived materials like asphalt, recycling & demolition waste.

Material is fed into the large feed hopper, common on both vibrating grizzly feeder & live pre-screen versions, both feature a selectable crusher bypass facility & optional fines discharge conveyor. Load sensing, ensures the wide crusher inlet opening receives a continuous feed of pre-screened material, avoiding unnecessary crusher wear.

The Powerscreen® Trakpactor 500's robust impact chamber features a twin apron, 4 bar rotor design, with hydraulic release aprons, hydraulic setting adjustment, hydraulic crusher overload & is driven directly off the engine via a HFO clutch for optimum fuel economy. Next crushed material passes; either over the independent under pan feeder & modular product conveyor, or directly onto the full length conveyor, both conveyors feature a raise/lower facility to aid clearance of rebar in the event of a blockage.

Where high volumes of finished end product are required, an optional single deck sizing post-screen with fines conveyor & oversize recirculation facility can be specified, this can be uncoupled quickly, lowers for maintenance & remains on the plant during transportation. Oversize material is returned to the crusher via the wide on-board recirculation conveyor which hydraulically folds for transport.

With its highly modular design construction, compact transport footprint (much shorter than many competitors) the Powerscreen® Trakpactor 500 can be tailored to suit the needs of all customers & makes it an ideal contract machine due to its impressive design features & high productivity.

- Output potential up to 500 tph (550 US tph)
- Suitable for a variety of feed materials, ideal for recycling, demolition & quarry applications
- Double deck grizzly feeder with under screen
- Load management system to control feeder speed
- Proven impact crusher with hydraulic overload protection, 4 bar rotor & twin apron design
- Fully independent under crusher vibrating pan feeder as standard
- Modular conveyor with raise/lower facility to aid clearance of rebar
- Latest generation power units that meet EU Stage IIIB / US Tier 4i & EU Stage IIIA / US Tier 3
- Chamber drive via clutch & highly fuel efficient direct drive system
- Crusher speed variation through user friendly PLC control system
- Live pre-screen & optional single deck 16' x 5' post-screen (SR)

Applications

Aggregate

- Blasted rock
- River rock

Recycling

- C & D waste
- Foundry waste

Mining

- Processed ores
- Processed minerals

All specifications subject to change without prior notice



Powerscreen® Trakpactor 500

Principal Components of the Powerscreen® Trakpactor 500 Impact Crusher



Principles of Operation

Material enters via the crusher opening & slides down the inlet chute where it is struck by the blow bar which is held within the rotor. This initial impact breaks the material which is then accelerated onto the top apron where more reduction takes place on impact. This material then falls back into the blow bars & the cycle repeated until the material is small enough to pass between the apron & the blow bar. Once through this gap, further reduction occurs on the bottom apron until the material can again pass through the gap & discharge from the underside of the crusher.

Any un-crushable material entering the chamber will relieve the overload cylinders & allow the material to pass. The cylinders will then return to the pre-set crushing position. The pre-set gap is adjusted by turning the adjustment spindle whilst the weight of the apron is held on the cylinder (hydraulic assist).

Crusher Specification

- Feed opening: 1360mm x 800mm (54" x 32")
- Max lump size* 500mm³ (20in³) / 860mm (34") diagonally / 1000x1000x200mm (39x39x8") slab
* depending on material & blow bar spec
- Rotor width: 1340mm (53")
- Rotor diameter: 1200mm (47")
- Number of aprons: 2
- Maximum clearance: 273mm (11") on both aprons
- Maximum OSS setting: 200mm (8") upper apron, 100mm (4") lower apron
- Minimum CSS setting: 75mm (3") upper apron, 35mm (1.4") lower apron
- Number of blow bars: 4
- Blow bar removal: Vertically
- Blow bar configuration: 2 full & 2 half (optional 4 full)
- Setting adjustment: Hydraulic assist
- Overload protection: Hydraulic
- Rotor speeds: 540 - 630rpm (34 - 40m/s) (111 - 131ft/s)
- Applications: Demolition / recycling / quarry
- Crusher weight: 14,855kg (32,750lbs)
- Full blow bar weight: 410kg (904lbs)
- Side Liners: 20mm thick, abrasive resistant steel

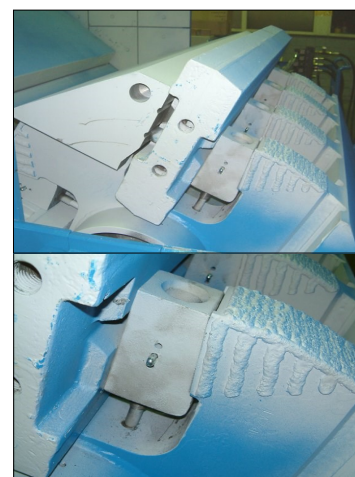

Views from inside the Trakpactor 500 Impact Crusher, showing blow bars, wedges & rotor

All specifications subject to change without prior notice



Powerscreen® Trakpactor 500

Powerscreen® Trakpactor 500 - Impact Crusher

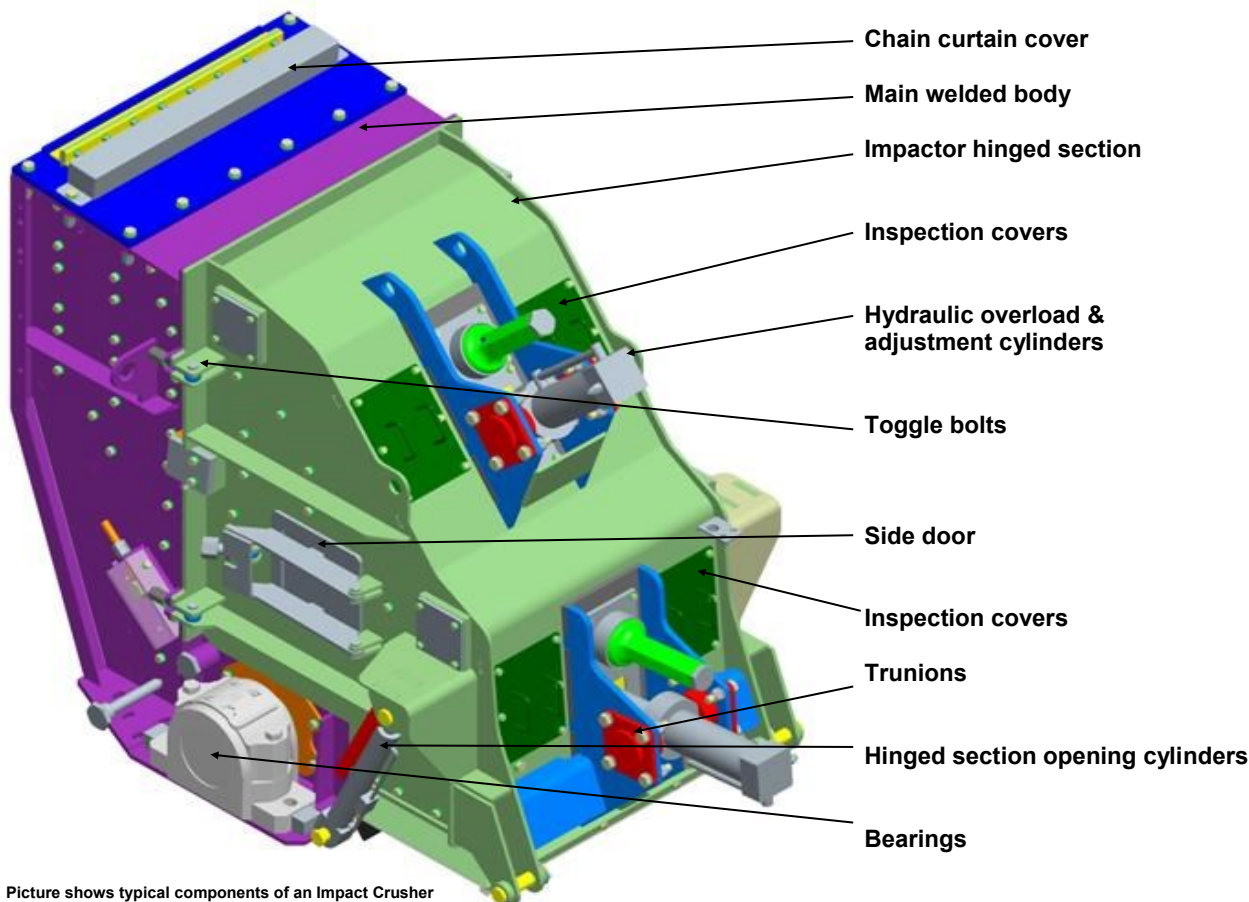

Picture shows typical components of an Impact Crusher

Main Features

- Crusher body:** Fabricated from steel plate & fully lined with replaceable abrasion resistant liner plates. Hinged side door allows access to apron tips & rotor for gap measurements & inspection. Complete hinged section opens hydraulically to allow blow bar removal & replacement, apron & liner replacement or major maintenance
- Rotor:** Cast steel & fitted with 4 reversible & replaceable blow bars
- Bearings:** Double row self aligning spherical roller bearing fitted each end of rotor
- Aprons:** Cast steel aprons with replaceable abrasion resistant wear plate on tip of bottom apron
- Drive:** Direct through wedge belts with tensioning system on the power unit
- Lubrication:** Rotor bearings are greased & fitted with inner & outer labyrinth seals
- Blow bars:** Standard blow bar is martensitic steel, options available in high chrome & ceramic

This plant is designed for both demolition & quarrying applications. When fitted with martensitic or ceramic blow bars the crusher will tolerate small quantities of steel reinforcing bar in the feed. However, the machine is not designed to accept large pieces of steel or other uncrushable objects, & the feed material should be assessed / inspected for suitability prior to crushing. It is vitally important that large pieces of steel or similar un-crushable objects are not allowed to enter the crushing chamber as severe damage & injury may occur. When high chrome bars are fitted, all steel should be removed from the feed material & the machine should only be used on quarry applications, or clean materials such as asphalt.

Powerscreen® Trakpactor 500

SPECIFICATION - Rev 11. 01-01-2017

Hopper

Hydraulic folding hopper with over centre struts & wedgelock system

Hopper length: 4.96m (16' 3")

Hopper width: 2.62m (8' 7")

Hopper capacity: 7m³ (9.2 cu. yd.)
Extensions: 10.5m³ (13.7 cu. yd.)

Body: 15mm thick abrasion resistant steel plate



Vibrating Grizzly Feeder

Type: Spring mounted vibrating

Vibrating unit: Twin heavy-duty cast eccentric shafts running in spherical roller bearings. Gears coupled at drive end.

Length: 4.26m (14')

Width: 1.38m (4' 6")

Pan: 12mm (0.5") thick abrasion resistant steel base plate liners

Drive: Flange mounted hydraulic motor

Grizzly: 2m (6'6") long double section of welded tapered finger bars at 34mm (1.3") nominal spaces fabricated in 20mm thick abrasion resistant steel. 50mm (2") nominal spacing also available

Mesh: Blanking mat standard, under screen mesh in sizes 25mm, (1"), 38mm (1.5") & 50mm (2") available

Chute: Plant is fitted with a bypass chute, with an internal two way flap door to control direction of fines, either forward onto the product belt or down onto the optional side conveyor, (if blanking mat is fitted)

Modular section: Hopper & feeder mounted on a removable modular sub frame

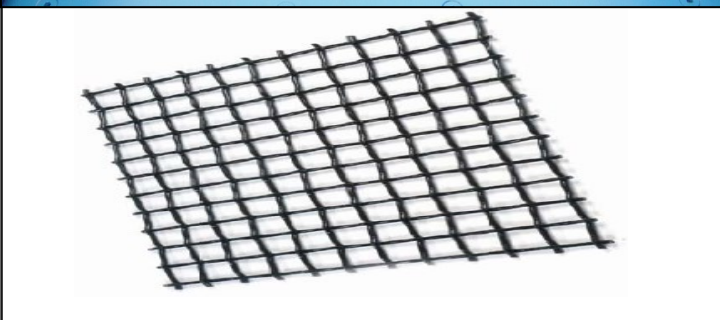

All specifications subject to change without prior notice



Powerscreen® Trakpactor 500

SPECIFICATION - Rev 11. 01-01-2017

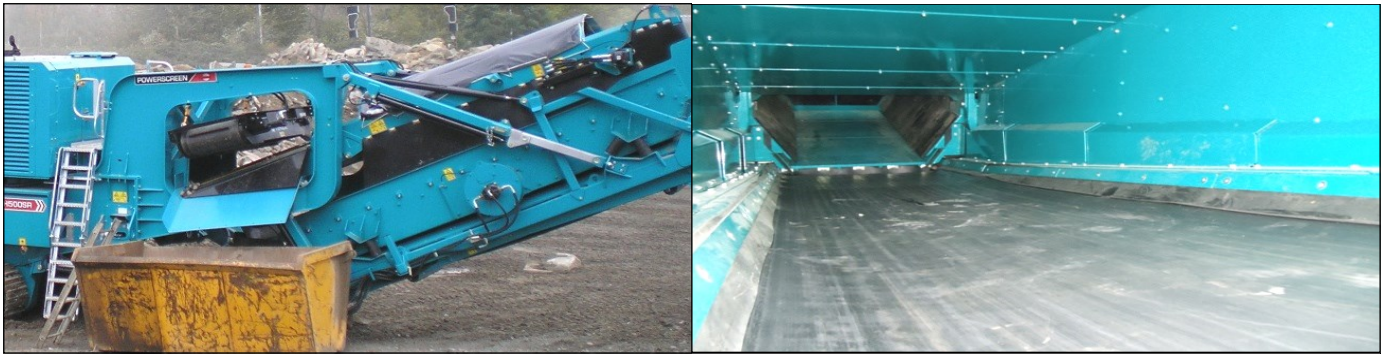

Product Conveyor

Conveyor type:	Fully removable modular unit with hydraulic raise & lower facility to increase clearance & simplify rebar removal. Can be operated whilst crushing. Shallow troughed with winged rollers & fully tunnelled with minimal snag areas
Belt type:	EP630/4 with 6mm top & 2mm bottom heavy duty rubber covers & vulcanised joint
Belt width:	1200mm (47")
Discharge height:	Standard 4.16m (13' 9") when fully raised (same on SR with post screen removed)
Stockpile volume:	107m ³ (140 cu. yd.)
Feedboot:	Fabricated steel with abrasion resistant steel liners
Impact area:	Under crusher pan feeder
Skirting:	Fully skirted in wear resistant rubber up to magnet discharge area
Drive:	Dual hydraulic motor direct to head drum
Lubrication:	Centralised grease points for lubrication of shaft bearings
Belt covers:	Canvas type removable dust covers, fitted over exposed sections of conveyor

Dust Suppression System

Spray bars with atomiser nozzles mounted over product conveyor & final conveyor discharge, piped to an inlet manifold for customer water supply or optional pump

Type:	Clean water multi atomising nozzles
Inlet:	Single point
Inlet pressure:	3 BAR (44 psi)
Water supply:	24 litres (6.3 g) per minute min
Frost protection:	Via system main valves
Pump:	Optional



All specifications subject to change without prior notice



Powerscreen® Trakpactor 500

SPECIFICATION - Rev 11. 01-01-2017

Power unit

Tier 3 / Stage 3A:	Caterpillar C-13 ACERT, 6 cylinder, 328 kW (440hp) at 1800rpm
Operating conditions:	Ambient temp. +30°C & -5°C (86°F & 23°F) altitudes up to 1000m (3281ft) above sea level. #
Operating rpm range:	1800 - 2100rpm
Emission control technique:	Not Applicable
Typical fuel consumption:	Non SR configuration 50-65 L/hr (13-17 US Gal/hr) SR configuration 65-80 L/hr (17-21 US Gal/hr)
Plant drive:	High quality pumps driven via belt drive
Clutch type:	Highly efficient, self-adjusting HPTO 12 dry plate clutch with electro hydraulic operation.

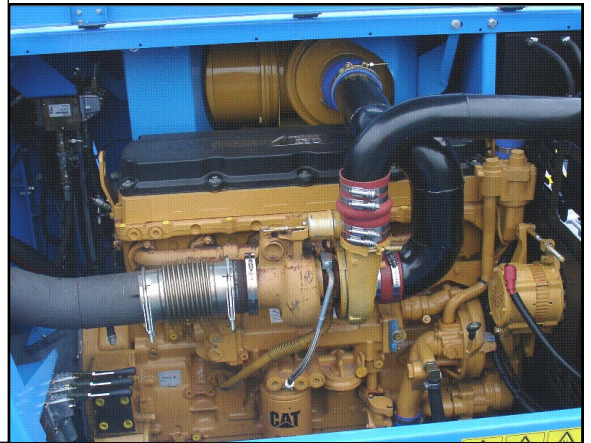

Tier 4F Stage IV:	Scania DC13 385A - 368kW (500hp)
Operating conditions:	Ambient temp. +30°C & -5°C (86°F & 23°F) altitudes up to 1000m (3281ft) above sea level. #
Operating rpm range:	1800 - 2100rpm
Typical fuel consumption:	N/A
Emission control technique:	Selective Catalytic Reduction (SCR)
Reductant tank size:	60 L (16.8 US Gal)
Plant drive:	High quality pumps driven via engine PTO's
Clutch type:	HPTO 12 wet clutch, electro hydraulic operation



Fuel tank capacity:	700 L (185 US Gal)
Hydraulic tank capacity:	540 L (140 US Gal)
Crusher drive:	Direct drive via wedge belts, Clutch pulley diameter 300mm (12"), Crusher pulley diameter 1000mm (39"). Crushing performance can be tuned, by changing engine speed between 1800 - 2100rpm on the PLC without significant loss of engine performance
Crusher drive tensioning:	Manually adjustable tensioners beside power unit

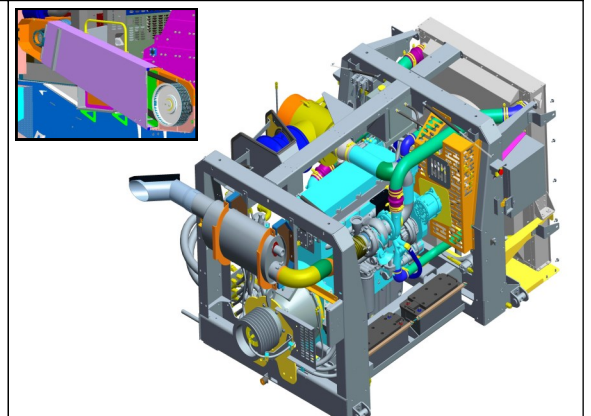

For applications outside this range please consult with Powerscreen as the plant performance / reliability may be affected

Selective Catalytic Reduction (SCR)

SCR technology is used for Stage IIIB & Tier 4i to reduce the NOX content in the exhaust gases. A chemical process is started by injecting reductant, a urea & water mixture, into the exhaust gas stream. During injection the water evaporates & the urea breaks down to form ammonia. The ammonia then reacts with the nitrogen gases in the catalytic converter & forms harmless products such as nitrogen gas & water

Through the use of SCR the exhaust gases are purged of poisonous levels of NOX in the best possible way. The reductant tank holds 60 litres & is heated by the engine's cooling system in order to avoid freezing of the urea solution, urea freezes at -11°C

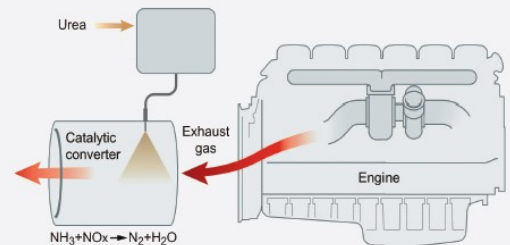

The principle for Scania SCR system

All specifications subject to change without prior notice



Powerscreen® Trakpactor 500

SPECIFICATION - Rev 11. 01-01-2017

Post-Screen & Fines Conveyor

Type:	16' x 5' single deck 2 bearing screen, side tension media
Drive:	Direct hydraulic motor (S + F)
Screen speed:	920rpm
Angle:	25°
Belt width:	1200mm (47")
Belt type:	EP400/3 4+2 covers
Discharge height:	3.84m (12' 7")
Stockpile volume:	84m ³ (110 cu. yd.)
Detach:	Quick detach fitted as standard



Cross Conveyor

Type:	Flat belt EP400/3 4+2 covers
Width:	650mm (26")
Drive:	Direct hydraulic motor
Transport:	Hydraulic retraction



Hydraulic Folding Recirculation Conveyor

Type:	Chevron belt EP315/3 3+1.5 covers
Width:	650mm (26")
Chevron:	25mm (1")
Drive:	Direct hydraulic motor
Stockpile:	From under cross conveyor, or via feed chute
Conveyor discharges into a feed chute mounted on the hopper which folds hydraulically for transport	



Transport

Retract cross conveyor, lower & retract after screen, lower product conveyor head section, this is all carried out by using manual hydraulic functions

The recirculation conveyor hydraulically folds upward against the machine to reduce width during transportation

The plant is now a one load transport which complies with required transport legislation

The hydraulic folding recirculation conveyor is not designed for stockpiling, an additional stockpiler (not supplied) needs to be installed under the cross conveyor



All specifications subject to change without prior notice



Powerscreen® Trakpactor 500

SPECIFICATION - Rev 11. 01-01-2017

Crawler Tracks

Type:	Heavy duty tracks, bolted to chassis on pads & pins
Track centres:	3.78m (12' 5") - Standard Version 4.2m (13' 9") - SR Version
Track width:	500mm (20")
Climbing grade:	30° maximum
High speed:	0.9kph (0.56 mph)
Low speed:	0.3kph (0.2 mph)
Drive:	Two integral hydraulic motors
Tensioning:	Hydraulic adjuster, grease tension

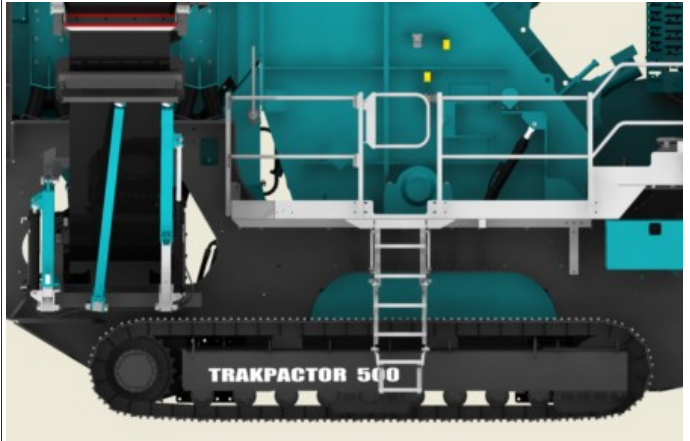

Guarding

Wire mesh or sheet metal guards are provided for all drives, flywheels, pulleys & couplings

The guards provided are designed & manufactured to CE & ANSI standards



Platforms

Platforms are provided for maintenance on one side of the feeder & Impactor, these are fitted with double row handrails & access ladders

Platforms are also provided to gain access to the rear of the crusher & power unit



Chassis

Heavy duty I-section of welded construction provides maximum strength & accessibility



All specifications subject to change without prior notice



Powerscreen® Trakpactor 500

SPECIFICATION - Rev 11. 01-01-2017

Plant Controls

Full PLC control system

Full colour backlit screen

Complete pictorial user controls

Multi-function backlit menu buttons

Full system diagnostics

Sequential auto start up

Main controls

- Engine/crusher speed
- Feeder (start/stop/speed)
- Product conveyor + pan feeder (start/stop)
- Screen/fines/cross/recirculating (SR only)
- Product conveyor raise/lower
- Side conveyor
- Crusher control/screen setup



Umbilical controls

An umbilical control unit is supplied with the plant

This is used to control the tracking function & is also fitted with a stop button for the plant

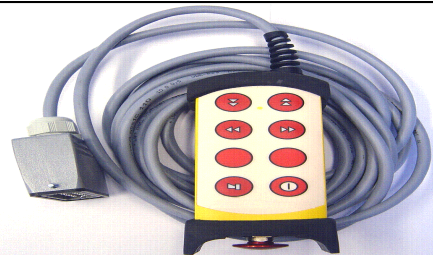

Optional Extras

- 2 deck live pre-screen
- Grizzly decks 38, 50, 63 & 75mm
- Punch plates cartridges 38, 50, 63 & 75mm
- Pre-screen meshes 25-75mm (1" - 3")
- Pre-screen & VGF blanking mats
- Side conveyor
- High chrome blow bars
- Ceramic blow bars
- 4 full size blow bars in lieu of 2 full 2 half blow bars
- Full length conveyor "under belt version"
- Single pole or twin pole over-band magnets
- Magnet prepared
- Post-screen meshes (sizes on request)
- Plant lighting
- Radio remote control
- Electric refuelling pump
- Optical belt weigher kits
- Hydraulic water pump for dust suppression
- Hot/Cold Climate Oils/Cooler Pack
- Hopper Extensions (10.5m3) (13.7cu.yd)
- Powerscreen Pulse

All specifications subject to change without prior notice



Powerscreen® Trakpactor 500 Options

SPECIFICATION - Rev 11. 01-01-2017

Side Conveyor

Conveyor type:	Troughed EP500/3 5+1.5 covers hydraulically folding
Width:	800mm (31.5")
Discharge height:	3.6m (11' 10")
Stockpile volume:	107m ³ (140 cu. yd.)
Drive:	Direct hydraulic motor
Lubrication:	Grease nipples on bearings
Position:	RHS only



Pan Feeder & Live Pre-screen

Vibrating pan feeder with 2 deck live pre-screen

Pan type:	Sprung vibrating pan
Vibrating unit:	Twin heavy duty cast eccentric shafts running in spherical roller bearings, gear coupled at drive end, flange mounted hydraulic motor
Dimensions:	Length: 2.8m (9' 2") Width: 1.28m (4' 3")
Pan:	10mm thick fully welded base plate with 10mm thick abrasion resistant liners

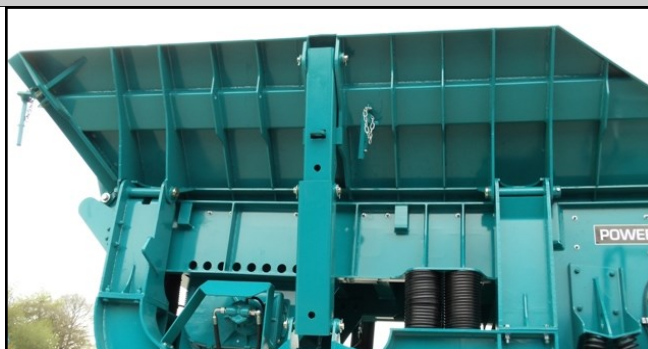

Pre-screen:	Sprung vibrating unit with stepped finger bofor deck
Vibrating unit:	Single shaft, out of balance weights, flange mounted hydraulic motor
Dimensions:	Length: 2.1m (6' 11") Width: 1.35m (53")
Bofor deck:	2 stepped bolt in cartridges with 1m (39") long self cleaning fingers 38mm (1.5") nominal spacing
Control:	Variable speed control though control panel & (radio remote optional)
Chute:	Bypass chute with internal 2 way flap door fitted, to control direction of fines, either forward onto the product belt or onto the optional side conveyor (if blanking mat is fitted)
Modular section:	Hopper & feeder mounted on removable modular sub frame



All specifications subject to change without prior notice



Powerscreen® Trakpactor 500 Options

SPECIFICATION - Rev 11. 01-01-2017

Optical Belt Weigher

Optical belt scale, monitors material volume, can be converted into mass & downloaded to hand held PDA unit via Bluetooth

PDA unit included in kit

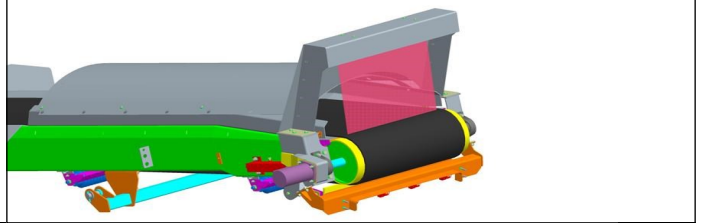

Single Pole & Twin Pole Magnets

Magnet type: Suspended self cleaning over band with endless belt

Magnet block: 836 x 530mm (33" x 21")

Drive: Direct drive hydraulic motor

Control: Pre-set variable speed

Discharge: Via stainless steel shedder plate

Magnet prepared: Also available



Radio Remote Control

Complete with integrated tracking functions & plant stop button.

NB— Only available in certain countries where type approval has been obtained

Remote can also be used to:

- Feeder (start/stop/speed)
- Product conveyor (raise/lower)
- Open top apron



Blow Bars

Standard blow bars supplied with plant are 2 full & 2 half martensitic steel. 2 further options are available:

High chrome: Suitable for medium to hard rock applications where no steel is present in the feed material. Good wear characteristics

Ceramic: Suitable for applications with limited steel in feed. Improved wear characteristics over standard martensitic blow bars

4 full blow bars: Available in all options



All specifications subject to change without prior notice



Powerscreen® Trakpactor 500 Options

Vibrating Pan Feeder

Type: Steel bodied vibrating feeder fitted with stainless steel liners, mounted under the crusher & designed to prevent any impact damage to the product conveyor

Width: Rear - 1160mm (53")
Front - 1250mm (49")

Length: 2400mm (103")

Drive: Twin hydraulic driven out of balance vibrator units

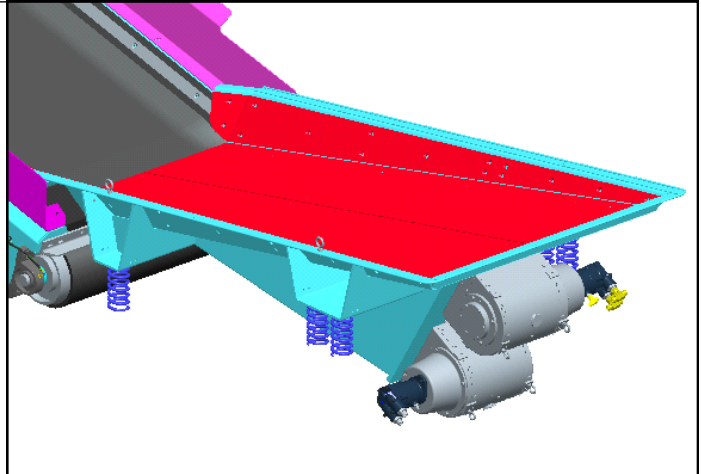

Hot/Cold Climate Oils

Cold climate oils - (Recommended for ambient temperatures between -20 to +30oC)

Hot climate oils - (Recommended for ambient temperatures between +15 to +50oC)



Control Panel Positive Pressurisation

An additional unit designed to reduce dust particles within the Control Panel.

A continuous flow of clean air is passed through the cabinet whilst the unit simultaneously filters out any particulate laden air.

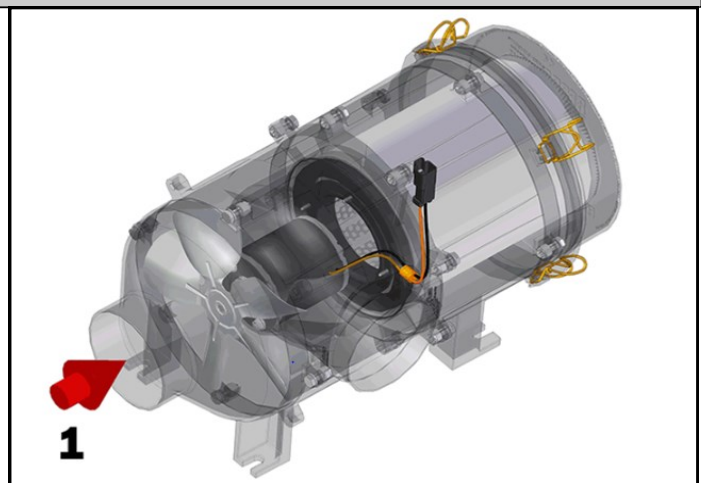

Powerscreen Pulse

Powerscreen Pulse is a system which allows the machine to relay performance and production data via phone networks, or by satellite when there's no cellular signal, to any device with a web browser, such as a PC, tablet or Smartphone.



Powerscreen® Trakpactor 500

SPECIFICATION - Rev 11. 01-01-2017

Approximate Plant Weights & Dimensions

Working length: 17.0m (56')
 Working height: 4.1m (13' 6")
 Working width: 7.0m (23') with side conveyor deployed

Transport length: 17.3m (56' 8")
 Transport height: 3.8m (12' 6")
 Transport width: 3.0m (9' 10")

Total plant weight: 52,580kg (115,919lbs) including side conveyor & standard magnet

500 Vibrating Grizzly Feeder, LHS Side Conveyor Transport & Working Dimensions

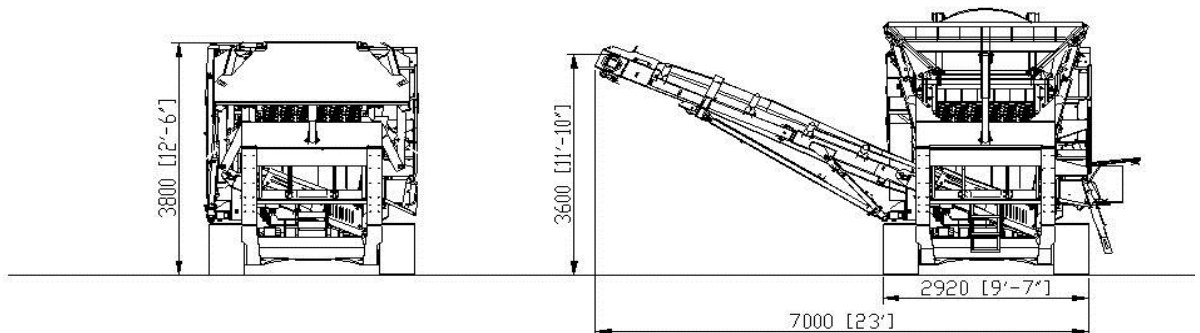
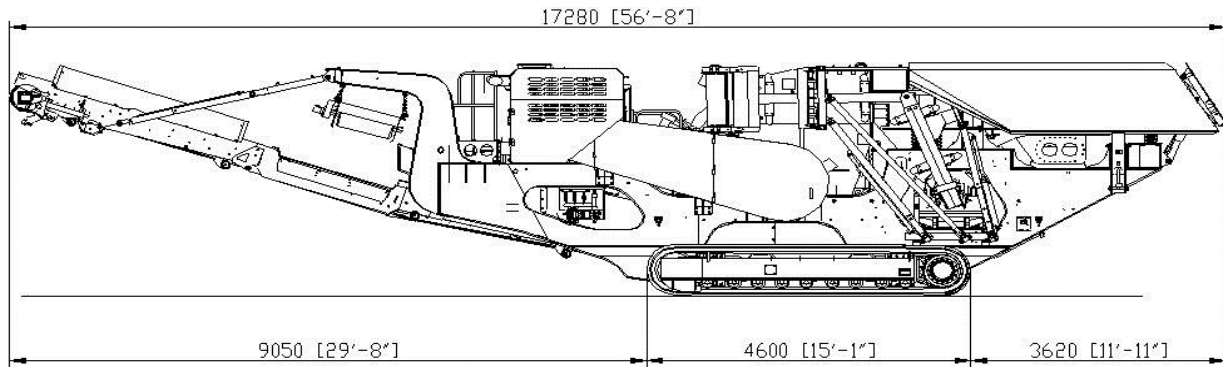
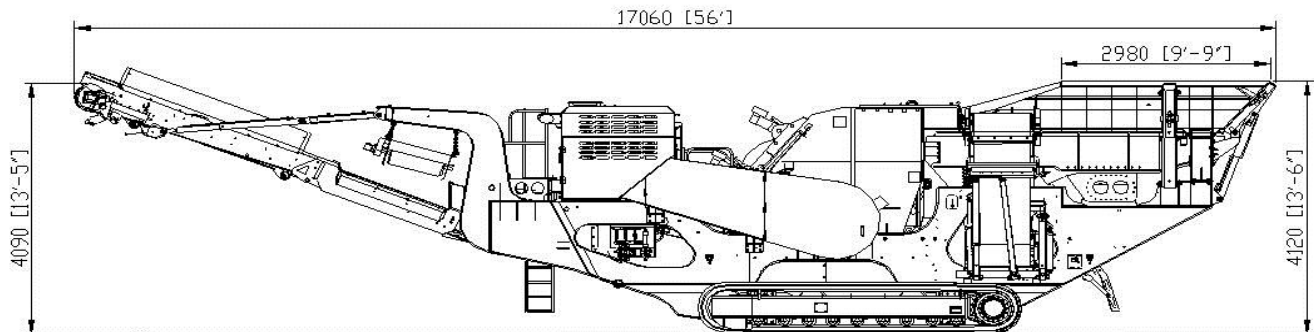

All specifications subject to change without prior notice



Powerscreen® Trakpactor 500

SPECIFICATION - Rev 11. 01-01-2017

Approximate Plant Weights & Dimensions

Working length: 17.6m (57' 9")
 Working height: 4.36m (14' 4")
 Working width: 7.0m (22' 11") with side conveyor deployed

Transport length: 17.9m (58' 8")
 Transport height: 3.8m (12' 6")
 Transport width: 3.0m (9' 10")

Total plant weight: 56,600kg (124,781lbs) including side conveyor & standard magnet

500, Live Pre-screen, LHS Side Conveyor Transport & Working Dimensions

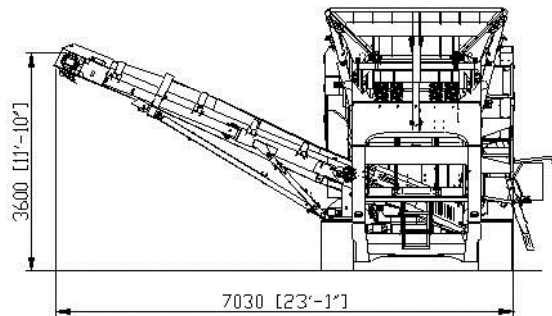
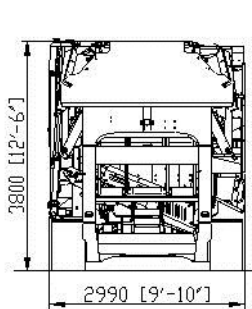
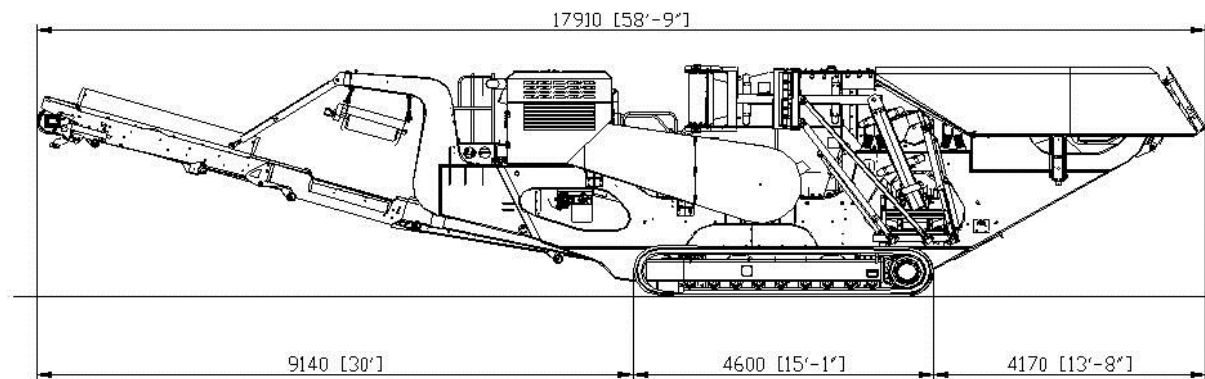
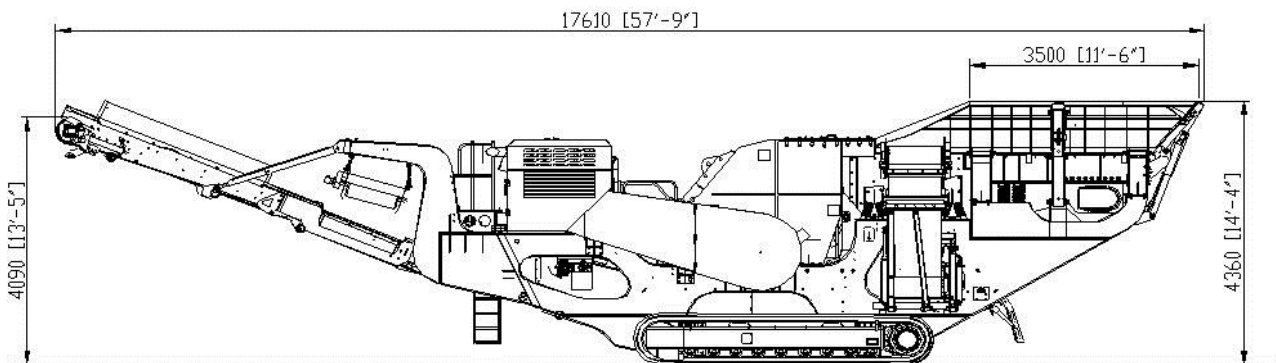

All specifications subject to change without prior notice



Powerscreen® Trakpactor 500SR

SPECIFICATION - Rev 11. 01-01-2017

Approximate Plant Weights & Dimensions

Transport length: 18.6m (61' 1")
Transport height: 3.8m (12' 6")
Transport width: 3.18m (10' 5")

Total plant weight: 67,000kg (147,710lbs) without side conveyor or magnet

500SR Live Pre-screen, RHS Side Conveyor, Post Screen & Hydraulic Folding Recirculation Conveyor, Transport Dimensions

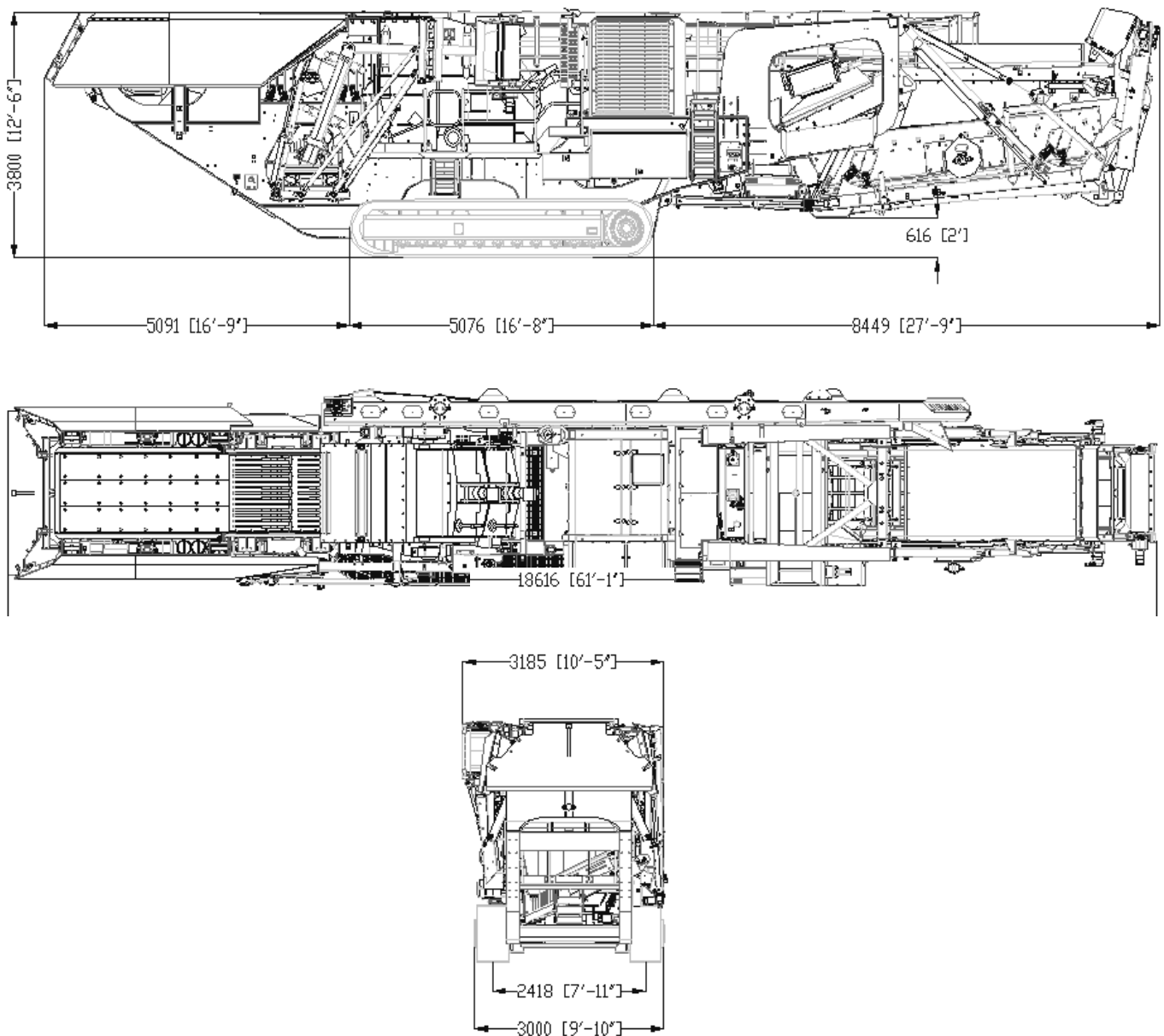

All specifications subject to change without prior notice



Powerscreen® Trakpactor 500SR

SPECIFICATION - Rev 11. 01-01-2017

Approximate Plant Weights & Dimensions

Plant (Less After Screen & Fines Conveyor), Load 1

Transport length:	18.3m	(60')	Post Screen & Fines Conveyor Removed
Transport height:	3.8m	(12' 6")	
Transport width:	3.2m	(10' 5")	
Est. weight:	62,000kg	(136,686lbs)	without side conveyor or magnet

Post Screen & Fines Conveyor, Load 2

Transport length:	6.3m	(20' 5")
Transport height:	3.0m	(9' 8")
Transport width:	2.5m	(7' 11")
Est. weight:	6,000kg	(13,227lbs)

500SR Live Pre-screen, RHS Side Conveyor, Post Screen & Hydraulic Folding Recirculation Conveyor Transported as 2 Loads

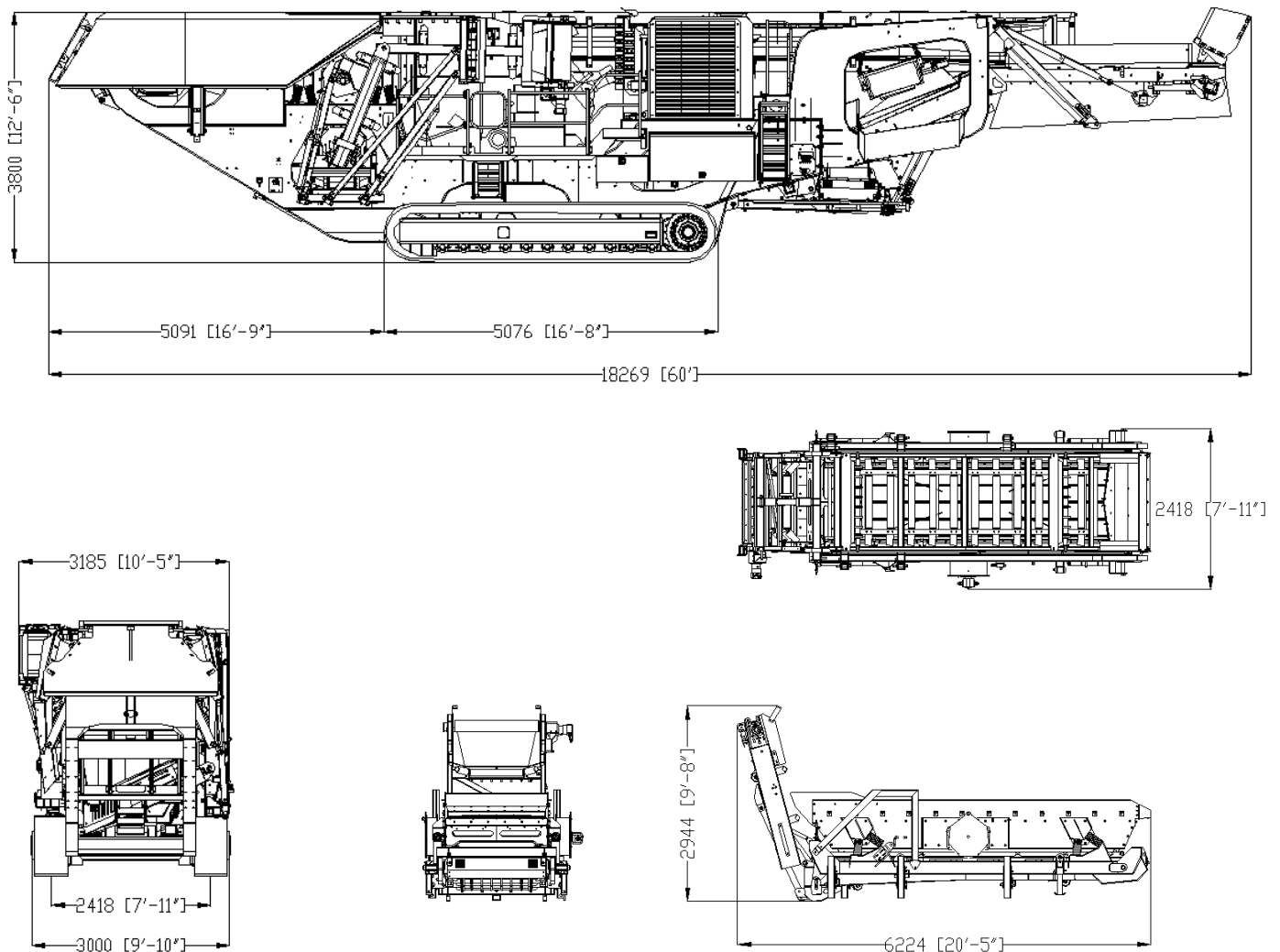

All specifications subject to change without prior notice



Powerscreen® Trakpactor 500SR

SPECIFICATION - Rev 11. 01-01-2017

Approximate Plant Weights & Dimensions

Working length:	20.7m	(67' 11")
Working height:	5.47m	(17' 11") - 4.36m (14' 4") over hopper sides
Working width:	7.1m	(23' 4") with side conveyor deployed
Total plant weight:	67,000kg	(147,710lbs) without side conveyor or magnet
Paint colour:	RAL 5021	

500SR Working, Live Pre-screen, RHS Side Conveyor, Post Screen & Hydraulic Folding Recirculation Conveyor, Working Dimensions

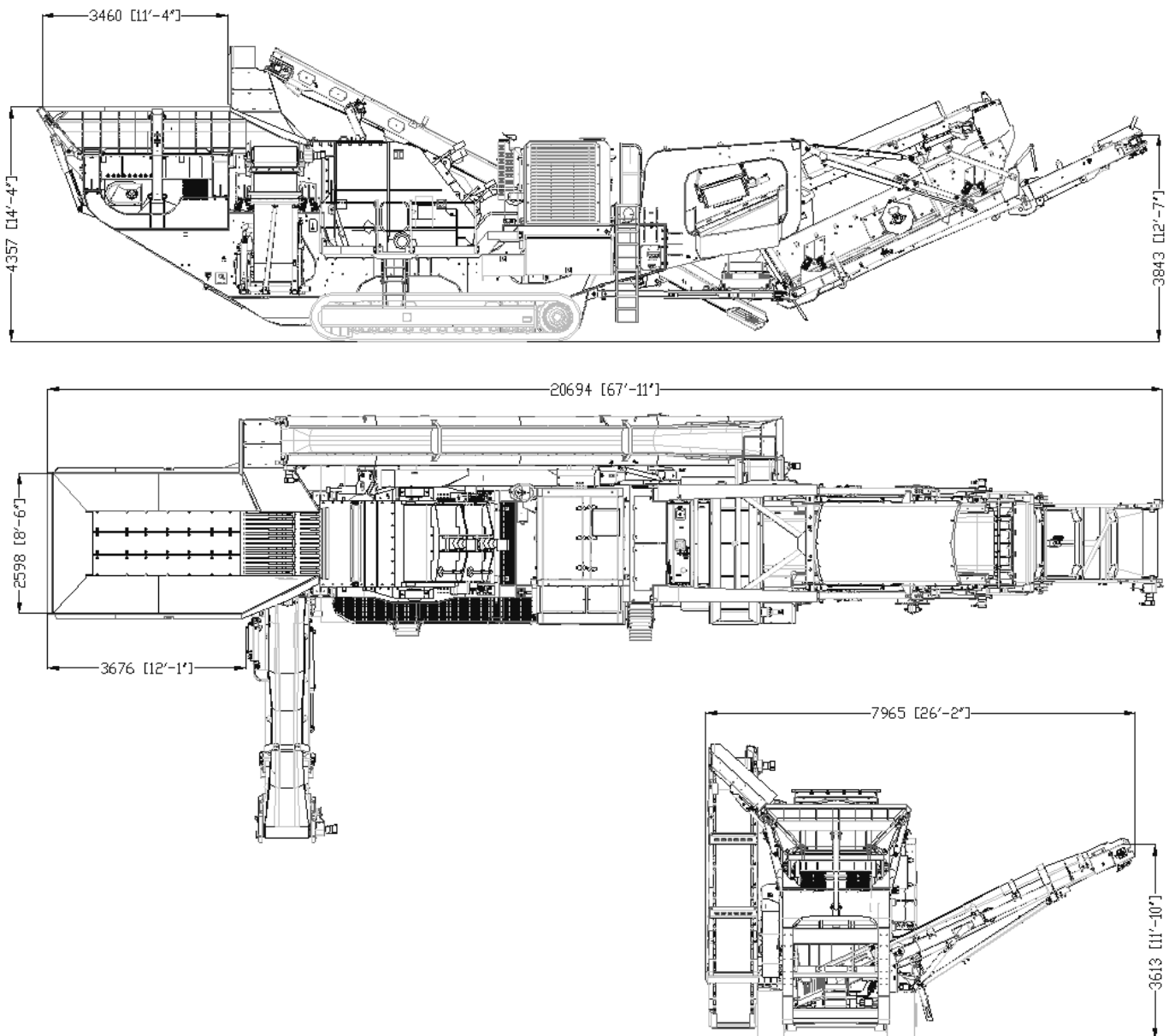

All specifications subject to change without prior notice



Powerscreen® Trakpactor 500SR

SPECIFICATION - Rev 11. 01-01-2017

Powerscreen equipment complies with CE requirements.

Please consult Powerscreen if you have any other specific requirements in respect of guarding, noise or vibration levels, dust emissions, or any other factors relevant to health and safety measures or environmental protection needs. On receipt of specific requests, we will endeavour to ascertain the need for additional equipment and, if appropriate, quote extra to contract prices.

All reasonable steps have been taken to ensure the accuracy of this publication, however due to a policy of continual product development we reserve the right to change specifications without notice.

It is the importers' responsibility to check that all equipment supplied complies with local legislation regulatory requirements.

Plant performance figures given in this brochure are for illustration purposes only and will vary depending upon various factors, including feed material gradings and characteristics. Information relating to capacity or performance contained within this publication is not intended to be, nor will be, legally binding.

Terex GB Ltd.
200 Coalisland Road
Dungannon
Co. Tyrone
Northern Ireland
BT71 4DR

Tel: +44(0) 28 8774 0701
Fax: +44(0) 28 8774 6569

E-Mail: sales@powerscreen.com
Web: www.powerscreen.com

Terex is a registered trademark of Terex Corporation in the United States of America and many other countries.
Powerscreen is a registered trademark of Terex GB Ltd in the United States of America and many other countries.

Copyright Terex Corporation 2017

All specifications subject to change without prior notice

